

- NOTES:
- 1 DIMENSIONS TO BE SYMMETRICAL ABOUT CENTERLINES WITHIN .010 TIR.
 - 2 EXTERIOR SURFACES FEATURE LIGHT TEXTURE.
 - 3 STANDARD LABEL RECESSES ARE AVAILABLE; CONTACT SUNFLOWER MANUFACTURING, INC. FOR DETAILS AND OPTIONS.
 - 4 ASSEMBLY HARDWARE PROVIDED.
 - 5 CUSTOM MACHINED HOLES, CUTOUTS, SCREEN PRINTING, GRAPHICS, AND OTHER CUSTOM SERVICES AVAILABLE FROM SUNFLOWER MANUFACTURING, INC.

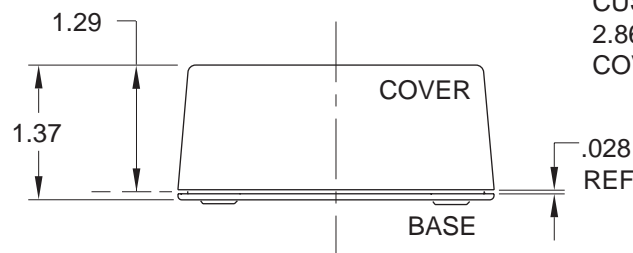
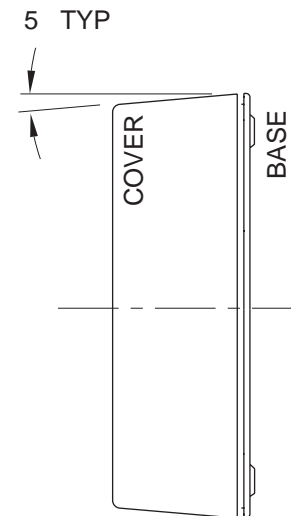
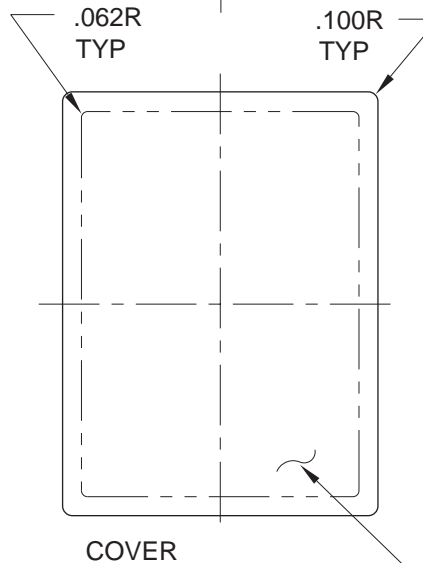
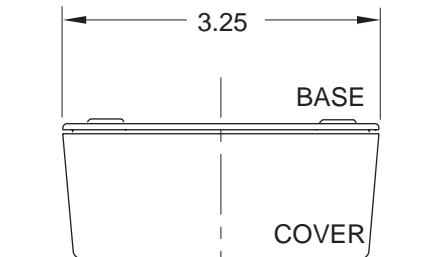
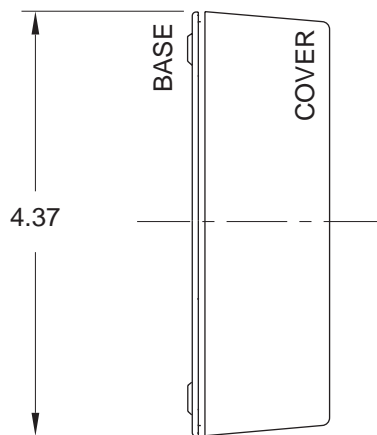
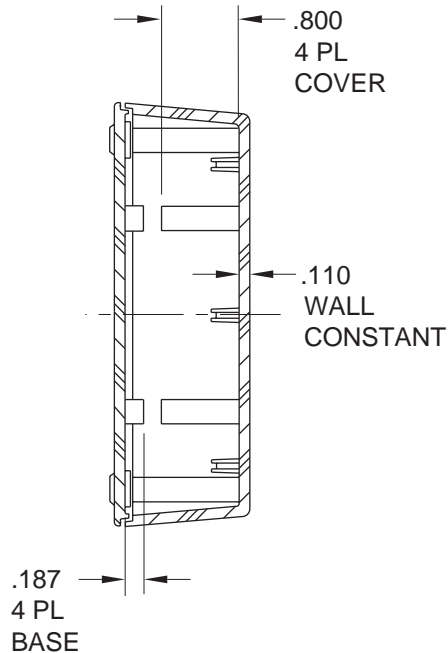

AREA AVAILABLE FOR
CUSTOM TOOLING MODIFICATIONS:
2.860 X 3.962
COVER AND BASE

NOTICE: THE INFORMATION AND DATA CONTAINED HEREIN IS CONSIDERED PROPRIETARY TO SUNFLOWER MANUFACTURING, INC., AND SHALL REMAIN THE EXCLUSIVE PROPERTY OF SUNFLOWER MANUFACTURING, INC. THE HOLDER WILL ASSUME CUSTODY AND CONTROL THAT THIS DOCUMENT WILL NOT BE COPIED, REPRODUCED, OR DISCLOSED WITHOUT THE EXPRESS WRITTEN CONSENT OF SUNFLOWER MANUFACTURING INC., POSSESSION OF THIS DOCUMENT DOES NOT CONSTITUTE A GRANT TO MANUFACTURE ANY ITEMS. DO NOT SCALE DRAWING.

DATE	LTR	REVISION	CHK

UNLESS OTHERWISE NOTED
DIMENSIONS ARE IN INCHES.

TOLERANCES ARE:

DECIMALS: .XX = .015

.XXX = .010

ANGLES: = 1 DEGREE

MATERIAL	
HIGH IMPACT ABS	
APPROVALS	DATE
DRAWN CC	10/6/95
CHECKED JWR	10/9/95
SCALE	SIZE
NONE	A

UNIBOX ENCLOSURES			
4330 SANTA FE ROAD		SAN LUIS OBISPO, CA 93401	
PHONE (805) 782-0200		FAX (805) 782-9501	
TITLE			
ENCLOSURE ASSEMBLY			
CUSTOMER INFORMATION DRAWING			
DWG	UNIBOX P/N #	128	SHEET 1 OF 2
REV	A		

**C.B. REFERENCE DIMENSIONS
NOT TO SCALE**

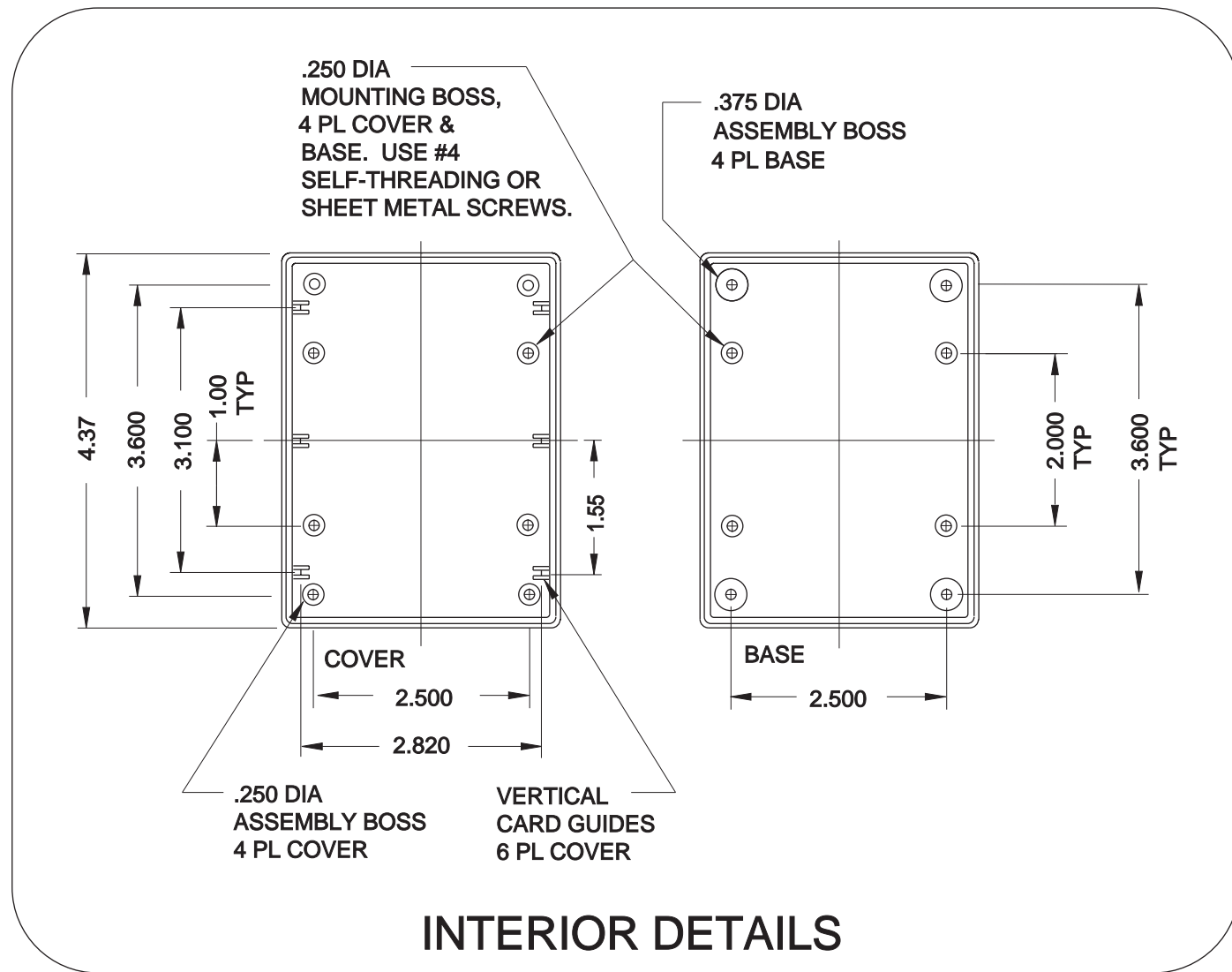
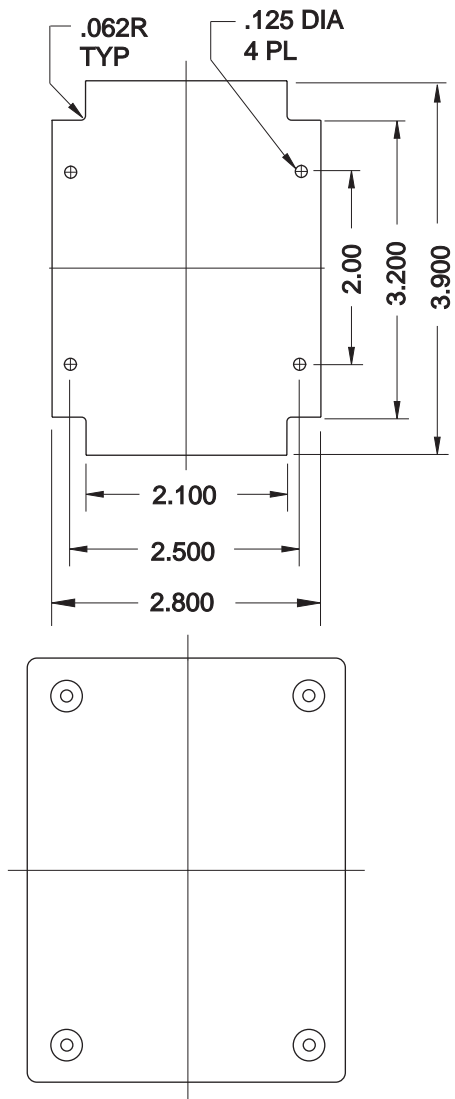

INTERIOR DETAILS

NOTICE: THE INFORMATION AND DATA CONTAINED HEREIN IS CONSIDERED PROPRIETARY TO SUNFLOWER MANUFACTURING, INC., AND SHALL REMAIN THE EXCLUSIVE PROPERTY OF SUNFLOWER MANUFACTURING, INC. THE HOLDER WILL ASSUME CUSTODY AND CONTROL THAT THIS DOCUMENT WILL NOT BE COPIED, REPRODUCED, OR DISCLOSED WITHOUT THE EXPRESS WRITTEN CONSENT OF SUNFLOWER MANUFACTURING INC.. POSSESSION OF THIS DOCUMENT DOES NOT CONSTITUTE A GRANT TO MANUFACTURE ANY ITEMS. DO NOT SCALE DRAWING.

DATE	LTR	REVISION	CHK

UNLESS OTHERWISE NOTED
DIMENSIONS ARE IN INCHES.

TOLERANCES ARE:

DECIMALS: .XX = .015
.XXX = .010

ANGLES: = 1 DEGREE

MATERIAL	
HIGH IMPACT ABS	
APPROVALS	DATE
DRAWN CC	10/6/95
CHECKED JWR	10/9/95
SCALE	SIZE
NONE	A

UNIBOX ENCLOSURES

4330 SANTA FE ROAD
PHONE (805) 785-0900

SAN LUIS OBISPO, CA 93401
FAX (805) 785-0948

TITLE
**ENCLOSURE ASSEMBLY
CUSTOMER INFORMATION DRAWING**

DWG UNIBOX P/N #	128	SHEET 2 OF 2	REV A
---------------------	-----	-----------------	----------